

Pin Retainers - Weld-on End Plates - Pin Tags

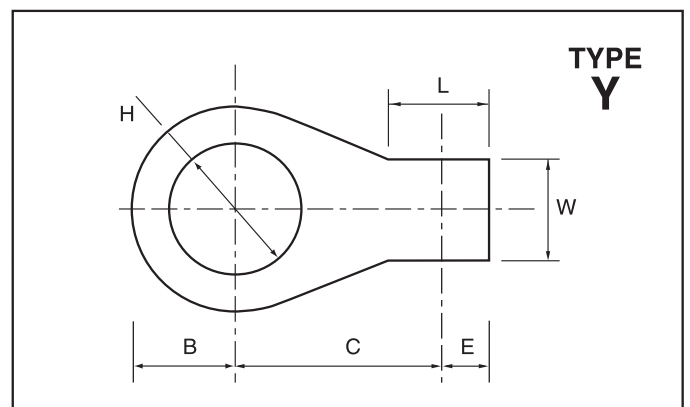
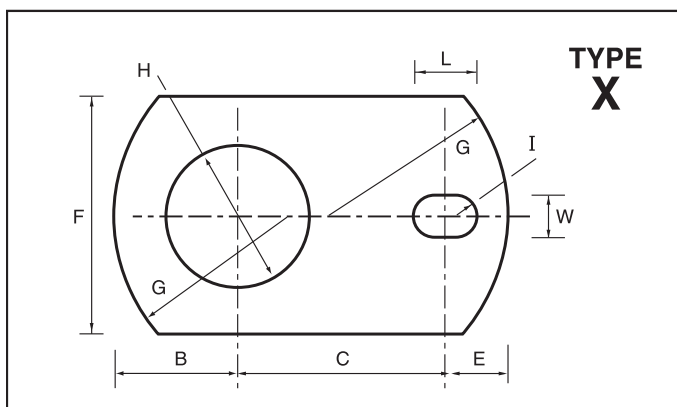
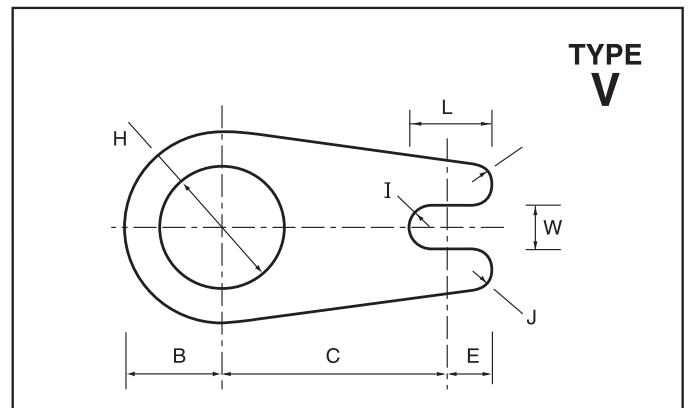
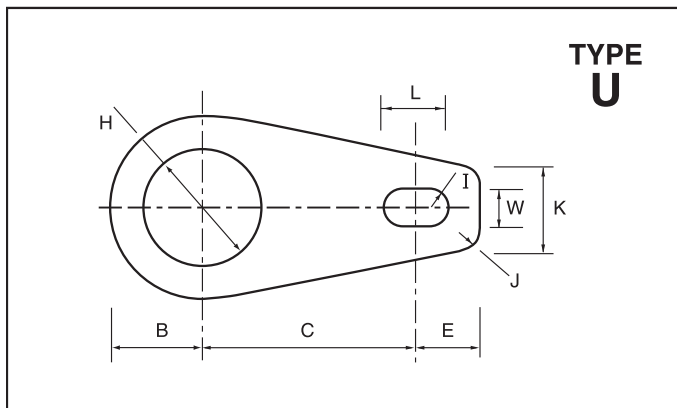
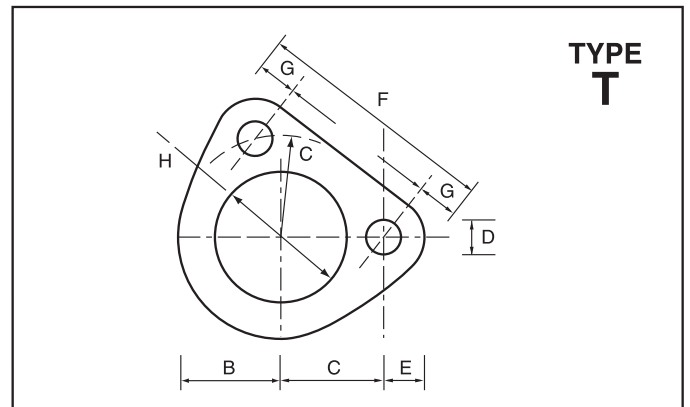
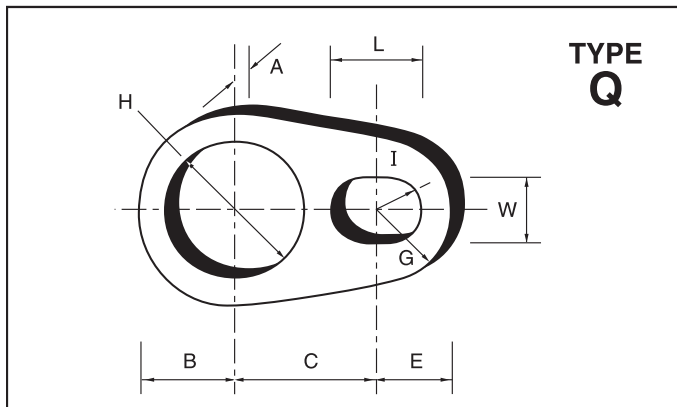
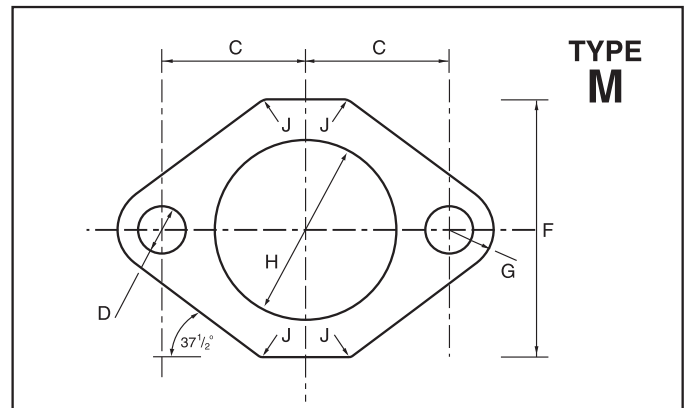
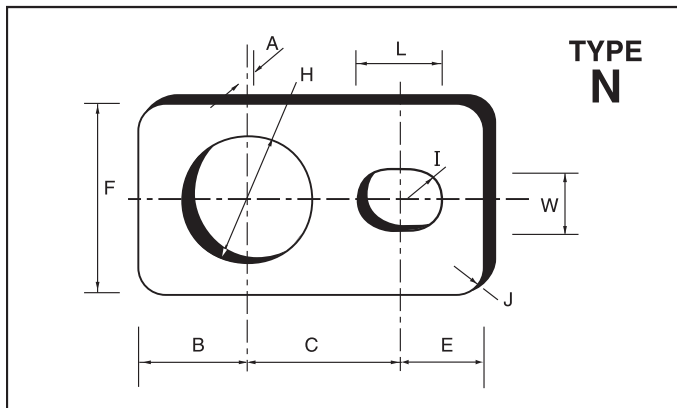

Pin Retainers - Weld-on End Plates - Pin Tags

PLATE TYPE SYMBOLS

- M = MANIFOLD FLANGE - TWO BOLT HOLES AT 80°
- N = RECTANGLE PLATE WITH BOLT HOLES
- Q = TEAR DROP SHAPE WITH BOLT HOLE
- R = ROUND FLANGE - NO BOLT HOLES
- T = TRIANGULAR FLANGE - TWO BOLT HOLES
- U = ROUND HEAD, TAPER SIDES, STRAIGHT END
- V = TEAR DROP SHAPE WITH OPEN END SLOT
- X = "RECTANGULAR" - STRAIGHT SIDES, CURVED ENDS PLUS BOLT HOLE
- Y = ROUND FLANGE WITH RECTANGULAR TAG
- Z = SQUARE PLATE - NO BOLT HOLES

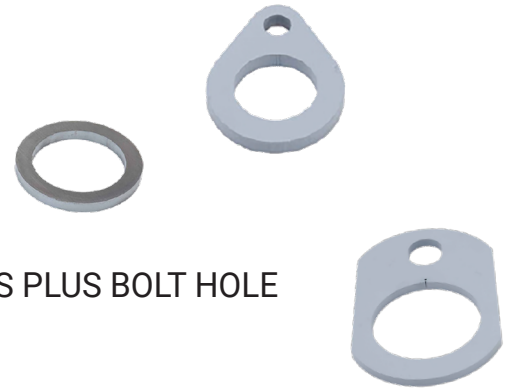

DIMENSION SYMBOLS - DIMENSIONS IN MILLIMETRES

- A = THICKNESS OF PLATE
- B = DISTANCE FROM CENTRE OF LARGE HOLE (PIN AXIS) TO NEAR END OF PLATE
- C = DISTANCE FROM PIN AXIS TO CENTRE OF BOLT HOLE
- D = DIAMETER OF BOLT HOLE - OR SLOT SHOWN AS Lmm x Wmm
- E = DISTANCE FROM CENTRE OF BOLT HOLE TO END OF PLATE
- F = WIDTH OF PLATE
- G = RADIUS AT SMALL END OF PLATE
- H = DIAMETER OF LARGE HOLE (WHERE PIN IS WELDED ON)
- I = RADIUS OF SLOT
- J = BLEND RADIUS
- K = WIDTH OF SMALL END OF TAPERED PLATES
- L = LENGTH OF SLOT OR RECTANGULAR TAG
- W = WIDTH OF SLOT OR RECTANGULAR TAG

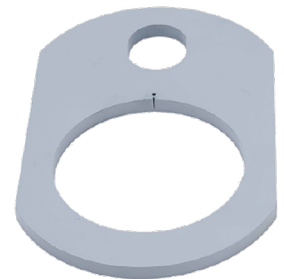

PART NUMBER SYSTEM FOR WELD-ON PLATES

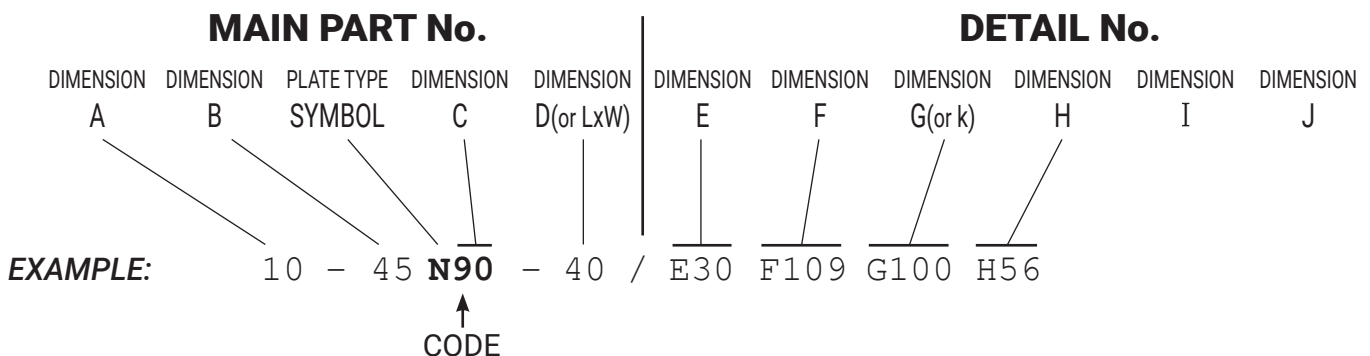

Excavator Pin End Plates Laser Cut

Plate Thickness	CODE	Price Ex GST	Pin Hole Diameter	
6 mm	46 M35	11 \$10	E11 F65 G11 H48	J10
8 mm	35 Q34	12 \$12	E12 - - H29	
8 mm	30 Q35	12 \$12	E12 - - H36	
6 mm	49 M37.5	\$11	E11 F75 G11 H58	J10
6 mm	35 U40	0 \$14	E0 - K70 H43	
6 mm	35 T39	13 \$14	E15 F90 G15 H48	
6 mm	20 Q40	16x13 \$20	E15 G15 H24	Popular
6 mm	40 T42.5	13 \$10	E15 F90 G15 H58	
6 mm	35 Q43	14 \$15	E18 - - H50	
6 mm	34 Q44	27x21 \$17	E26 - G26 H30	
8 mm	24 V44	\$10	E8 H37	
6 mm	22.5 X45	14 \$10	E22.5 F45 H23	
8 mm	42 Q49	0 \$10	E15 - G15 H50	
6 mm	33 Q50	27x23 \$28	E21 - G21 H44	
6 mm	25 U50	23x11 \$24	E20 - K25 H30	
16 mm	38 N51	33 \$24	E26 F76 H55	
8 mm	40 V52	25x16 \$18	H58	
8 mm	32.5 V57	25x20 \$18	E12.5 L25 W20 H44	J7
10 mm	28 X57	32x27 \$22	E25 F76 G50 H45	
6 mm	41 X58	35x30 \$26	E30 F75 G50 H46	129
12 mm	40 Y58	34x30 \$28	E17 H46	
6 mm	36 X59	36x30 \$26	E30 F75 G50 H45	
6 mm	40 X60	36x30 \$30	E30 F90 G60 H55	
6 mm	33 Q60	14 \$20	E15 - - H48	
6 mm	25 Q61	15x10 \$20	E14 L15 W10 H35	
8 mm	45 Y62	30x20 \$20	E15 L30 W20 H58	
16 mm	46 Y69	38x38 \$25	E19 L38 W38 H61	134
8 mm	44 Q70	21x13 \$22	E19 - G19 H63	
8 mm	35 V71	32x27 \$20	E16 L32 W27 H48	
10 mm	45 V72	32x13 \$20	E13 L32 W13 H56	
16 mm	46 Y71	38x38 \$23	E19 L38 W38 H66	136
12 mm	43 V77	44x25 \$30	E22 VolvoL120F H42	
10 mm	45 Q77	40x30 \$30	H55	
16 mm	35 Q79	31 Dia \$30	E25 G25 H37.5	
10 mm	53 Q80	38x32 \$30	E33 G30 H60.5	
10 mm	50 V80	40x25 \$40	E20 F100 H65	
8 mm	50 X80	48x40 \$40	E42 F100 G95 H63	
10 mm	53 Q81	38x32 \$30	E33 G30 H60.5	
10 mm	53 X81	42x32 \$34	E38 F100 G95 H66	
12 mm	55 V82	37x28 \$30	E18 VolvoL120F H70	
10 mm	50 X82	44x40 \$34	E40 F100 G95 H72	
16 mm	62 Y81	38x38 \$18	E19 L38 W38 H95	

Steel Laser Cutting Sydney

Complete Profiling Services

Laser cut profiles to 12mm thick

Precision Machine

Plasma cut profiles up to 25mm thick

Clean Finish Steel Profiles

Construction Base Plates

Phone 02 9912 5100

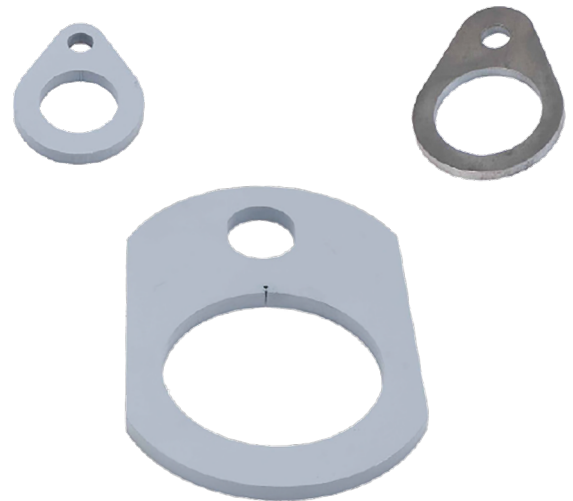

Wholesale Prices shown for \$170 Minimum order

Retail: POA \$130 Min order

Plus freight & GST. All prices subject to change without notice

Newcastle - Sydney Region - Australia

Excavator Pin End Plates Laser Cut

Steel Laser Cutting Sydney

Complete Profiling Services

Laser cut profiles to 12mm thick

Precision Machine

Plasma cut profiles up to 25mm thick

Clean Finish Steel Profiles

Construction Base Plates

Phone 02 9912 5100

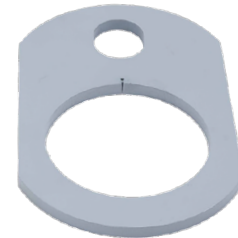

Plate Thickness	CODE	Price Ex GST	Pin Hole Diameter						
12 mm	40 Y83	30x30 \$30	H40						
8 mm	35 V83	24x16 \$15	H46	E12	J8	K48			
20 mm	56 Y84	46x38 \$48	H66	E23	L46	W38		160	
8 mm	56 Q85	21x13 \$25	H82	E22	G22				
12 mm	55 U85	50x40 \$30	H67	E45	I=20	J20		K80	
20 mm	55 Y85	34x40 \$60	H76	E17	L34	W40		160	
20 mm	66 Y86	26x40 \$60	H86	E13	L26	W40		163	
20 mm	60 Y87	25x40 \$60	H86	E13	L25	W40		160	
20 mm	65 Y88	25x40 \$60	H96	E13	L25	W40		166	
8 mm	35 V88	32x27 \$30	H48	E16	L32	W27			
12 mm	44 V89	50x30 \$39	H48	E25	L50	W30		I=15,J8	
12 mm	85 X89	48x40 \$24	H80		F125			200	
20 mm	60 Y89	34x38 \$28	H76	E17	L32	W38			
12 mm	37 N90 ³¹	\$16	H44	E37	J8	F80			
20 mm	60 Y90	50x40 \$64*	H76	E25	L50	W40		175	
10 mm	35 Q90	22x16 \$22	H46	E25	-	G25			
12 mm	68 X90	48x40 \$40	H81	E42	L48	W40		200	
10 mm	42 Q91	22x16 \$30	H56	E24	-	-		155	
20 mm	60 Y91	40x40 \$64	H86	E20	L40	W40		170	
12 mm	68 N91	48x40 \$20	H91	E42	L48	W40			
12 mm	68 X91	48x40 \$40	H91	E42	L48	W40		200	
12 mm	42 Q92	33x28 \$34	H48	E50	G25	I14			
12 mm	61 X92	44x40 \$40	H91	E38	F125	G100		190	
12 mm	50 X95	40x30 \$40	H70	E38	F100	G80			
20 mm	67 Y96	28x38 \$64	H106	E14	L28	W38		177	
8 mm	41 Q97	13 \$22	H46	E22		G22			
16 mm	45 N100	16 \$26	H49	E26	F90	J15			
8 mm	49 Q100	35x33 \$28	H66	E25	-	G25			
10 mm	40 Q100J	14 Ø \$34	H46	E20	-	G20			
12 mm	65 Q101	48x40 \$34	H75	E44	L48	M40			
20 mm	60 Y100	50x40 \$64	H86	E25	L50	W40		185	
20 mm	70 Y101	52x52 \$64	H110	E26	L52	W52		196	
12 mm	39 X102	44x30 \$30	H55	E42	F80	G80		183	
18 mm	60 Y103	35x65 \$50	H85	E18				181	
12 mm	50 Q105	28x20 \$40	H58	E25	G25	I10			
10 mm	38 X105	40x30 \$40	H46	E42	F80	G80		183	
12 mm	95 Y105	80x100 \$50	H136	E40	L80	W100			
10 mm	38 X107	40x30 \$40	H55	E36	F80	G80		183	
16 mm	42 Y107	45x39 \$50	H65	E22	L45	W39		172	

Indexation of Grease Exits to End Plates

Plate is viewed with pin hidden, as viewed on the machine, or as by a person welding the plate.

The long end of the PLATE (or bolt hole end) at 12 o'clock, (or pointing away from person welding).

The grease exit position on the circumference is described in an o'clock position, ie, for pin at right: 3 o'clock.

Unless specified, assume grease exit is at 6 o'clock, abbrv: "clk".

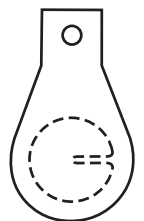

Newcastle - Sydney Region - Australia

Excavator Pin End Plates Laser Cut

Steel Laser Cutting Sydney Complete Profiling Services

Laser cut profiles to 12mm thick
Precision Machine

Plasma cut profiles up to 25mm thick
Clean Finish Steel Profiles
Construction Base Plates

Phone 02 9912 5100

Plate Thickness	CODE	Price Ex GST	Pin Hole Diameter	
18 mm	80 Y108	24x38 \$46	E12 L24 W38	H96 200
16 mm	50 N110	0 \$28	E20 F101 -	H67
12 mm	65 N111	43 \$28	E30 F125	H90
16 mm	47 Y111	40x40 \$36	E20 L40 W40	H76 176
12 mm	51 X114	52x40 \$40	E39 F102 G70	H70 204
10 mm	45 Q115	20x13 \$30	E19 G19	H58
12 mm	51 X115	40x30 \$40	E36 F100 G70	H85 200
12 mm	57 X116	32 \$40	E28 F100 G70	H95
12 mm	65 U117	66x32 \$40	E45 J25 K80	H
12 mm	70 X119	48x40 \$54	E36 F150 G100	H106 225
12 mm	75 Y119	60x80 \$54		H116 225
12 mm	84 Q120	40x48 \$52	E38 F150	H106 242
12 mm	70 X120	48x40 \$54	E35 F150 G100	H117 225
12 mm	97 X121	48x40 \$54	E38 F150 G100	H117 255
12 mm	85 Y122	75x100 \$56	E38	H136 245
18 mm	70 Y124	62x45 \$65	E31 L62 W45	H78
20 mm	69 Y126	52x52 \$65	E26 L52 W52	H105
20 mm	68 Y127	60x60 \$65	E30 L58 W60	H106 225
20 mm	72 Y130	60x60 \$65	E30 L60 W60	H116 232
20 mm	75 Y133	35x54 \$65	E17 L35 W54	H94 225
12 mm	100 X130	55x45 \$60	E50 F180 G100	H136 280
16 mm	65 U144	0x0 \$40	E16 K32	H106 225
16 mm	65 Q148	46 \$46	E35	H76
16 mm	65 Q149	46 \$38	E35 C150	H86 250
16 mm	65 Q150	46 \$40	E35	H106 250
12 mm	55 X150	52x40 \$52	E20	H
12 mm	46 X151	52x43 \$52	E51 F160 G125	H81
20 mm	85 Y150	40x50 \$65	E20 L40 W50	H102 254
20 mm	75 Y154	35x40 \$50	E17 L35 W40	H125 244
12 mm	120 X160	55x45 \$90	E55 F230 G120	H156 335
16 mm	60 Y163	62x50 \$55	E30 L60 W50	H71 253
20 mm	53 Y195	70x48 \$96	E35 L70 W48	H84 283x130
12 mm	68 V196	50x32 \$46	E35 L51 W32	H66
20 mm	69 Y199	60x50 \$60	E25 L60 W50	H76 298
20 mm	83 Y203	64x44 \$60	E32 L64 W44	H109 318
20 mm	75 Y205	50x50 \$60	E25 L50 W50	H96 305

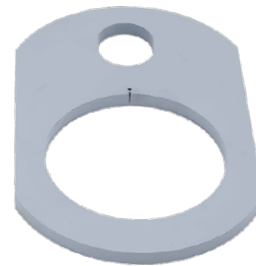

TYPE X



TYPE Q

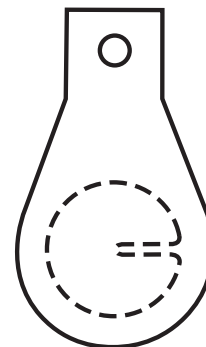

TYPE Y

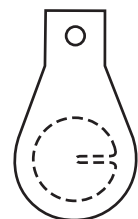

Indexation of Grease Exits to End Plates

Plate is viewed with pin hidden, as viewed on the machine, or as by a person welding the plate.

The long end of the PLATE (or bolt hole end) at 12 o'clock, (or pointing away from person welding).

The grease exit position on the circumference is described in an o'clock position, ie, for pin at right: 3 o'clock.

Unless specified, assume grease exit is at 6 o'clock, abbrv: "clk".

Newcastle - Sydney Region - Australia

Excavator Pin End Plates Laser Cut

Laser Cut Steel Rings - Weld-On End Plates - Spacers

Plate Thickness	Outside Ø	Pin Hole Diameter	CODE	Price Ex GST
6 mm	35 Ø	23 Ø	H23	\$12
6 mm	50 Ø	28 Ø	H28	\$12
6 mm	58 Ø	33 Ø	H33	\$12
mm	Ø	Ø	H34	\$12
12 mm	55 Ø	37 Ø	H37	\$12
6 mm	64 Ø	38 Ø	H38	\$12
6 mm	80 Ø	38.6Ø	H39	\$14
6 mm	66 Ø	40 Ø	H40a	\$13
6 mm	56 AF, 76 Ø	40 Ø	H40	\$13
8 mm	60 Ø	40 Ø	H41	\$12
6 mm	66 Ø	42 Ø	H42	\$12
mm	Square	Ø	H43	\$12
12 mm	66 Ø	44 Ø	H44	\$16
7 mm	76 Ø	46 Ø	H46	\$14
6 mm	72 AF	48 Ø	H48	\$12
10 mm	72 AF	48 Ø	H49	\$12
6 mm	90 Ø	56 Ø	H56	\$13
12 mm	75 Ø	57 Ø	H57	\$23
12 mm	90 Ø	58 Ø	H58	\$20
12 mm	76 Ø	60 Ø	H60	\$20
8 mm	92 Ø	60 Ø	H61	\$20
12 mm	110 Ø	61 Ø	H62	\$48
10 mm	120 Ø	65 Ø	H65	\$20
12 mm	100 Ø	66 Ø	H66	\$20
12 mm	86 Ø	67 Ø	H67	\$20
12 mm	125 Ø	71 Ø	H71	\$50
12 mm	115 Ø	76 Ø	H76	\$24
20 mm	170 Ø	80 Ø	H80	\$30
12 mm	150 Ø	81 Ø	H81	\$56
12 mm	120 Ø	86 Ø	H86	\$26
20 mm	180 Ø	90 Ø	H90	\$30
12 mm	160 Ø	91 Ø	H91	\$60
12 mm	130 Ø	96 Ø	H96	\$24
12 mm	175 Ø	102 Ø	H102	\$70
12 mm	145 Ø	106 Ø	H106	\$30
12 mm	190 Ø	112 Ø	H112	\$80
12 mm	155 Ø	116 Ø	H116	\$65
12 mm	210 Ø	122 Ø	H122	\$80
12 mm	230 Ø	132 Ø	H132	\$90
12 mm	245 Ø	142 Ø	H142	\$98



Steel Laser Cutting Sydney Complete Profiling Services

Laser cut profiles to 12mm thick
Precision Machine

Plasma cut profiles up to 25mm thick
Clean Finish Steel Profiles
Construction Base Plates

Phone 02 9912 5100

Newcastle - Sydney Region - Australia

Economy Shim Kits - Steel Bucket Shims

<u>PART No.</u>	<u>PRICE</u> Ex GST	<u>OUTSIDE</u>	<u>INSIDE</u>	<u>WEIGHT</u>	<u>THICKNESS</u>	<u>SHIM KITS</u>
SM26	\$ 40	50 mm	26.0 mm	0.14 kg	1mm, 2mm, 3mm	2 of each per Kit
SM31	\$ 44	55 mm	31.0 mm	0.16 kg	1mm, 2mm, 3mm	2 of each per Kit
SM33	\$ 44	63 mm	33.0 mm	0.22 kg	1mm, 2mm, 3mm	2 of each per Kit
SM36	\$ 44	70 mm	36.0 mm	0.27 kg	1mm, 2mm, 3mm	2 of each per Kit
SM41	\$ 50	74 mm	41.0 mm	0.28 kg	1mm, 2mm, 3mm	2 of each per Kit
SM46	\$ 50	80 mm	46.0 mm	0.32 kg	1mm, 2mm, 3mm	2 of each per Kit
SM51	\$ 61	96 mm	51.2 mm	0.49 kg	1mm, 2mm, 3mm	2 of each per Kit
SM56	\$ 58	95 mm	56.0 mm	0.44 kg	1mm, 2mm, 3mm	2 of each per Kit
SM61	\$ 64	100 mm	61.0 mm	0.47 kg	1mm, 2mm, 3mm	2 of each per Kit
SM66	\$ 68	115 mm	66.0 mm	0.66 kg	1mm, 2mm, 3mm	2 of each per Kit
SM71	\$ 69	120 mm	71.0 mm	0.70 kg	1mm, 2mm, 3mm	2 of each per Kit
SM77	\$ 66	127 mm	77.0 mm	0.76 kg	1mm, 2mm, 3mm	2 of each per Kit
SM81	\$ 69	130 mm	81.0 mm	0.77 kg	1mm, 2mm, 3mm	2 of each per Kit
SM86	\$ 70	138 mm	86.0 mm	0.87 kg	1mm, 2mm, 3mm	2 of each per Kit
SM91	\$ 74	146 mm	91.0 mm	0.97 kg	1mm, 2mm, 3mm	2 of each per Kit
SM96	\$ 70	150 mm	96.0 mm	0.99 kg	1mm, 2mm, 3mm	2 of each per Kit
SM102	\$ 76	155 mm	102.0 mm	1.01 kg	1mm, 2mm, 3mm	2 of each per Kit
SM106	\$ 76	160 mm	106.0 mm	1.07 kg	1mm, 2mm, 3mm	2 of each per Kit
SM111	\$ 76	165 mm	111.0 mm	1.11 kg	1mm, 2mm, 3mm	2 of each per Kit
SM116	\$ 80	178 mm	116.0 mm	1.35 kg	1mm, 2mm, 3mm	2 of each per Kit
SM121	\$ 80	185 mm	121.0 mm	1.45 kg	1mm, 2mm, 3mm	2 of each per Kit
SM126	\$ 85	192 mm	126.0 mm	1.56 kg	1mm, 2mm, 3mm	2 of each per Kit
SM131	\$ 94	210 mm	131.0 mm	2.1 kg	1mm, 2mm, 3mm	2 of each per Kit
SM141	\$100	220 mm	141.0 mm	2.2 kg	1mm, 2mm, 3mm	2 of each per Kit
SM151	\$120	240 mm	151.0 mm	2.6 kg	1mm, 2mm, 3mm	2 of each per Kit
SM161	\$120	250 mm	161.0 mm	2.8 kg	1mm, 2mm, 3mm	2 of each per Kit

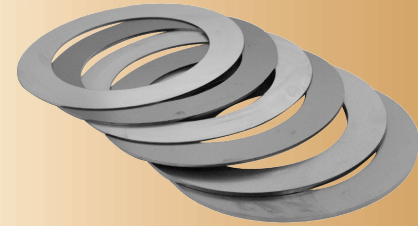

Australian Made Shims
Excavator Bucket Shims
Rebuild Shims
Steel Spacer Shims
Shim for Komatsu Loader
WA Loader Shims
Steel Bucket Shims
Excavator bucket shims
Laser Cut Shim Kits
Shims for Earthmoving
Precision Laser Cut
Shims to Perth Overnight
Plant Repair Shims
Shims Newcastle
NSW made Shim Kits
Shim for Hitachi Excavator
Shims for Kobelco
Tasmania Shim Supplier
Overnight Kalgoorlie
Mt Isa Shim Supplies
Shims Ex Stock
Shims NZ 2 Days
Shims Canada 4 Days
Shims for 90 Ø Shaft

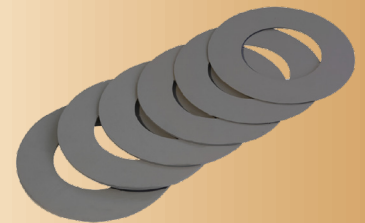

Shims to suit Caterpillar
Precision Laser Cut Shim Kits

Wholesale Prices
shown for \$170
Minimum order

Retail: POA
\$130 Min order

Plus freight & GST. All prices
subject to change without notice



12mm Spacers on Page 73